

Industrial Fires and Explosions



Fire and Explosion in Dust Collector

Sparks and burning embers in dust collection systems are a major cause of fires and explosions.

Spark arrestors are the first line of defense.

You need a RELIABLE inline spark arrestor.



QUENCHER™ Inline Spark Arrestor

Not all spark arrestors are created equal and do not comply with NFPA 69; Standard on Explosion Prevention Systems.

QUENCHER™ spark arrestor IS compliant with NFPA 69.

Beware of low cost units and imitators that do not meet the NFPA 69 standard.

See technical bulletin E-075, NFPA 69 and Quencher Spark Arrestor.



Q096, 8 foot diameter Quencher spark arrester



Mini-Quencher spark trap

MINI-QUENCHER is for 2 to 4 inch vacuum tubing systems, 100 to 500 CFM

QUENCHER™

In-line Spark Arrester

- NEW IMPROVED in 2019
- Only NFPA 69 compliant spark arrester on the market
- For all industrial dust collection systems
- A wide selection of standard models; 6 to 120 inch duct diameters and up to 200,000 CFM
- UNLIMITED custom designs for any duct connection size and air flow (CFM or M³/HR) required. Example; a sectional unit for 1,500,000 CFM.

An essential safety device; for any industry, including welding, grinding & metal working, flame spray, plasma & laser arc cutting, powder spray, mixing of stratified air in ducts, furnace & boiler exhausts, foundry, woodworking.

QUENCHER™ in-line Spark Arrester developed in 2003- 2005, as revolutionized in-plant safety by providing a cost effective method to eliminate sparks that cause dust collector fires and explosions. **QUENCHER** has expanded its reach by way of unmatched performance and reputation, attributed to application experience and superior engineering know-how. With thousands of units in operation worldwide, **QUENCHER** unquestionably maintains its place as the leader in spark arresting technology. **QUENCHER** is the most complete and proven product line in the world.

Unique Features

- **Newly redesigned in 2019;** after unparalleled success since 2005, now we have lower stable pressure drop in operating range, greater performance safety factor for smaller sizes, simplified internal design to lower the cost.
- **Complies with NFPA 69** Standard on Explosion Prevention Systems, the only spark arrester that does, see bulletin E-075.
- Most advanced technology, introduced January 2005, adapted from proven mist eliminator technology dating back to the 1960 era and patented in the 1890s.
- **In-line passive device** (no dropout to a dust bin); easy to apply, install and use.
- Designed specifically to extinguish and cool sparks & embers.
- Prevents fires & explosions, which are common in dust collection systems.
- **No moving parts;** static device, no power required.
- **Low to no maintenance.**
- **Automatic Cell Cleaner;** only available with the QUENCHER. See page 2.
- Quencher options (not applicable to Mini-Quencher): Stainless steel, high temperature (up to 2000^oF), corrosion and abrasion resistant treatments, floor-mount stand, ceiling mount bracket, access port, slip/sleeve joint or rolled edge adapters
- **Unlimited duct size and/or air flow range to meet any job requirement.**

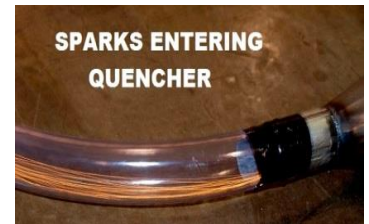

Sparks Eliminated

Description

QUENCHER is designed and built specifically for spark arresting/cooling. It is not an air blending / air mixing device falsely applied to spark cooling, as other imitators are sold as. The “Cell” consists of concentric & overlapping radial curved turbulation vanes in a round housing, which gives the air a violent full 90^o turn, thereby creating maximum agitation / turbulence of the air stream. This is the secret of spark/ember arresting.

A static device, having no moving parts, requires no power and little to no maintenance.

“Cell only” models, without the inlet and outlet reducer sections are also available.

Duct Connections: For the QUENCHER; flanged is standard, non-standard inlet/outlet size/configuration is available. For the MINI-QUENCHER, it is a slip/sleeve connection.



Internal view of the QUENCHER cell

Manufactured by; QAM, 11312 US 15-501 North, Suite 107-182, Chapel Hill, NC, 27517

Phone 1-800-267-5585 toll-free; www.QAManage.com

How It Works (in dust collection systems)

Refer to the figure below. The spark is surrounded by an envelope of hot air. The envelope keeps the spark in contact with oxygen which fuels the spark / burning ember. The gas in the envelope is less dense than the gas in the gas stream; therefore, it is buoyed up and floats along in the gas stream. By design, the flow in the duct is laminar so the spark/ember and its envelope move along in the gas stream undisturbed, at the same velocity as the gas stream. The spark/ember may be carried for hundreds of feet. Eventually it reaches the dust collector and the spark gets deposited on the filter media surface or in the hopper where it will ignite flammable dust or combustible media. The QUENCHER creates extreme turbulence which breaks apart the hot air envelope, stripping the oxygen (fuel) away from the burning spark/ember, therefore extinguishing and cooling it. The temperature of the spark is now too low to cause an ignition and cooled sparks are carried safely along the gas stream to the dust collector.

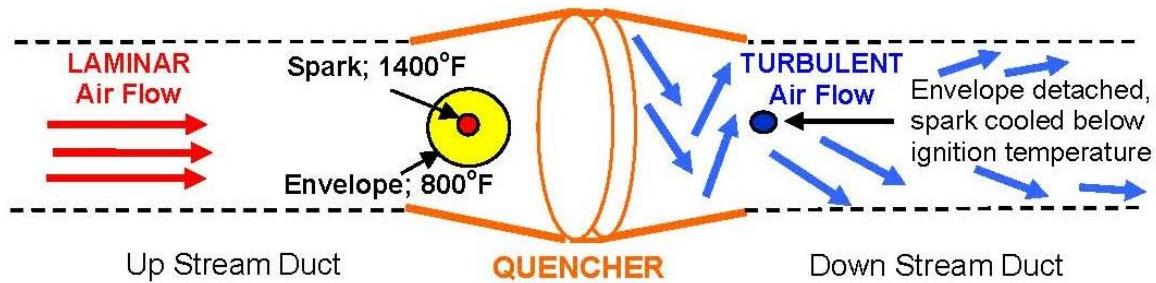

- **Design quirk;** you cannot upsize or downsize models by simply a dimensional ratio, as our competitors try to do. It won't work! Each model must have its own specific blade profile, to be effective.
- **Air mixing or air blending devices,** which are marketed as spark arrestors/coolers, do not create enough turbulence and have gaps in the cells permitting sparks to slip through.
- **CAUTION; for conditions other than standard air** (70°F, 0% RH or moisture, sea level, and refrigeration cycle effects), consult factory/engineering. Selection of any spark arrester must be done by a professional who knows how to make necessary adjustments when dealing with conditions other than ideal standard air.

We tried other spark arrestors in the past that proved to be less than 100% effective on preventing fires on source capture plasma and laser table applications but since we have switched to the Quencher, our customers have not had any fires in their dust collectors. *Dave Deasy*

Automatic Cell Cleaner

(Supplied exclusively with the QUENCHER spark arrester)

Newly redesigned in 2019; simpler and less costly cell cleaners.

This is a **safety issue**, not at all related to the spark arrester performance, which is commonly ignored.

Part of OSHA & NFPA 69 compliance: It is important for the Quencher cell to be kept free of combustible dust. Accumulations, from heavy dust loading, could cause a fire and void the warranty.

Sometimes dust and dirt can dropout in the duct work or within the QUENCHER cell itself. To help reduce the issues associated with dust accumulations, an optional **CELL CLEANER / BOOSTER** device can be supplied in front of the Quencher cell. It is built as an integral part of the QUENCHER, to ensure critical orientation, jet distances and ease of application. This device can be actuated manually or automatically to give a burst of air into the duct and Quencher, thereby blowing the dust down the duct to be safely collected at the dust collector. For more information, get the technical bulletin, "Auto Booster – Duct Cleaner".

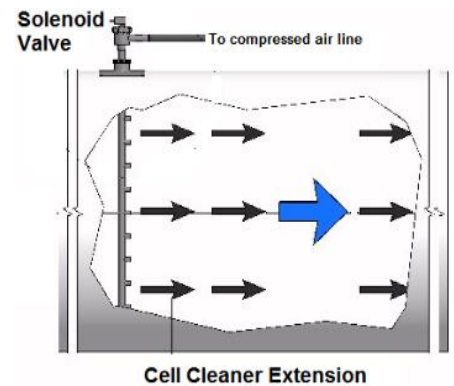

View the “Quencher Video” on our website; www.QAManage.com

Manufactured by; QAM, 11312 US 15-501 North, Suite 107-182, Chapel Hill, NC, 27517

Phone 1-800-267-5585 toll-free; www.QAManage.com

Mini-Quencher

In-line Spark Arrestor

For 2" to 4" vacuum tubing systems, 100 to 500 CFM



Q-2, spark trap for 2" vacuum system



SPARKS ENTERING
QUENCHER



NO SPARKS LEAVING
QUENCHER

An essential safety device to prevent fires; for welding, grinding & metal working etc

QUENCHER™ In-Line Spark Arrestor was developed in 2003 to 2005 and as a result revolutionized in-plant safety by providing an effective method to eliminate sparks that cause dust collector fires and explosions. The **Mini-Quencher** was added in 2015. **QUENCHER** has expanded its reach by way of unmatched performance and reputation attributed to application experience and superior engineering know-how. With thousands of units in operation worldwide, **QUENCHER** unquestionably maintains its place as the leader in spark arresting technology with the most complete and proven product line in the world.

Unique Features

- **Complies with NFPA 69** Standard on Explosion Prevention Systems, the only spark arrestor that does. See engineering bulletin E-075.
- Most advanced technology available since January 2005.
- Specifically designed to extinguish sparks & embers, not a re-named air mixer.
- Helps prevent fires & explosions; common in dust collection systems.
- **Static device; no moving parts, no power required.**
- In-line device (no dropout to a dust bin); easy to apply, install and use.
- Robust and abrasion resistant; Made of 14 gage HRS tube and internal components.
- **Duct Connections:** Standard is sleeve joint / slip on.
- The "Cell" consists of overlapping turbulence deflectors in a round housing, thereby creating maximum agitation and turbulence of the air stream. Turbulent energy is the key to spark arrestance.
- Low to No maintenance.

Q-x; Mini-Quencher Specifications

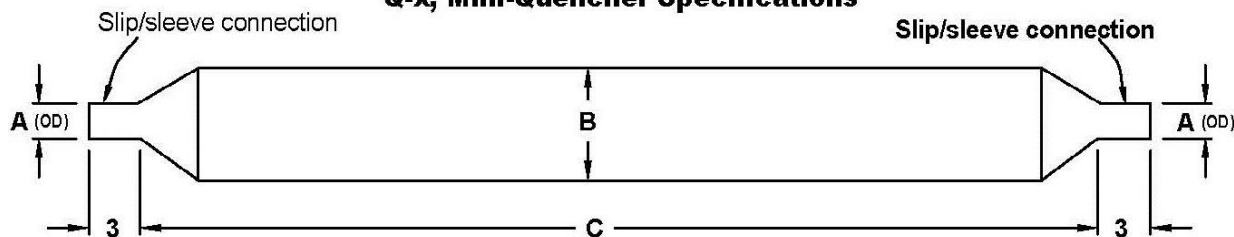

Dimensions; inches, cubic feet per minute, pounds					
Model	CFM (1) Min - Max	A diam.	B diam.	C	Weight
Q-2	100-150	2	4	23	10
Q-3	130-340	3	5	26	18
Q-4	300-500	4	6	37	25

(1) for conditions other than standard air (70 degF, sea level), consult factory / engineering.

Manufactured by; QAM, 11312 US 15-501 North, Suite 107-182, Chapel Hill, NC, 27517
Phone 1-800-267-5585 toll-free; WWW.QAMANAGE.COM

Standard QUENCHER Spark Arrestor

For common ducted dust collection

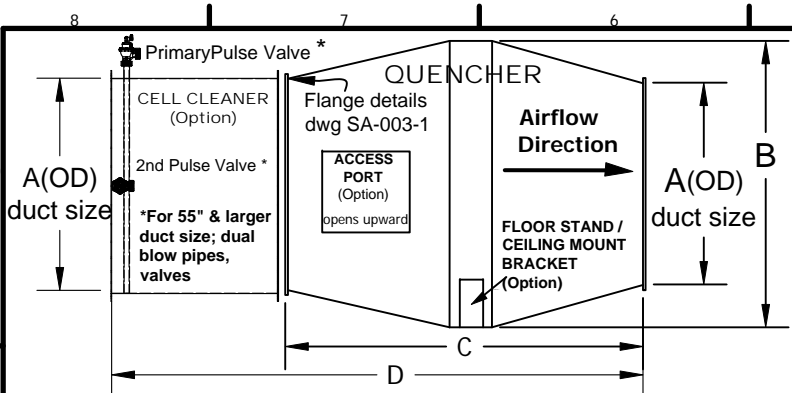

Any custom duct size can be supplied.

Dimensions: cubic feet per minute, inches, pounds

MODEL	SCFM (1) min - max	A diam.	B (2) diam.	C	D	ACCESS PORT	WEIGHT	WEIGHT with cell cleaner
Q008	500-810	6	8	14	29	n/a	10	21
Q010	800-1300	8	10	14	37	n/a	16	31
Q011	960-1600	8	11	18	37	n/a	18	35
Q014	1500-2400	10	14	24	47	n/a	30	57
Q016	2100-3300	12	16	24	47	n/a	44	69
Q020	3000-4900	14	20	34	61	9x9	68	98
Q024	4900-7600	16	24	42	77	10 x 10	89	128
Q026	5400-9000	18	26	42	77	10 x 10	95	140
Q030	7200-11,900	22	30	44	79	10 x 10	135	193
Q038	11,500-19,200	28	38	54	91	12 x 12	211	301
Q048	18,500-30,500	36	48	64	107	12 x 12	333	468
Q060	29,000-47,500	44	60	80	129	18 x 18	688	913
Q072	42,000-69,000	54	72	92	147	18 x 18	945	1305
Q084	57,000-94,000	62	84	106	161	18 x 18	1305	1710
Q096	74,000-123,000	72	96	118	175	24 x 24	1890	2520
Q108	93,500-155,500	80	108	130	190	24 x 24	2745	3465
Q120	115,500-191,500	88	120	152	212	24 X 24	3987	4764

CONSTRUCTION:

- Built to; ISO 9001-2008 and CWB certified
- Three styles are available;
 - QUENCHER STANDARD MODEL (Qxxx); includes transitions upstream and downstream to duct size.
 - QUENCHER CELL ONLY (QCxxx); can be inserted into an existing duct, of equal diameter.
 - MINI-QUENCHER; for high pressure vacuum systems
- Products are built to North American compliance with EPA, OSHA, NFPA, SMACNA round duct standards. Compliance with local codes and standards, and accuracy of order to job site operating conditions are the responsibility of the purchaser.
- HRS welded construction; Q008 to Q048 = 14 gauge, Q060 to Q084 = 12 gauge, Q096 to Q120 = 10 gauge, good up to 650°F. Special construction available; SS=304 & 316 stainless steel, MD=medium duty for temperature above 650°F, HD=heavy duty for abrasion and tough applications.
- Reducer-transition sections are supplied at both the inlet and outlet of the Quencher cell with a slope not to exceed 15°. These transition sections are designed to adapt the QUENCHER to the most common duct sizes. Other duct sizes are available upon request.
- Paint Finish; Terra Brown RAL8028, outside surfaces, alkylne degreased, iron phosphate chemical etch, Q008 to Q072 are powder coated, Q084 TO Q120 are primed and top coat painted two part epoxy, good to 250°F. Special high temperature, corrosion and abrasion resistant finishes available upon request.
- Flanges and bolt pattern are according to the drawing SA-003 Flanges & Adapters. Others are available with purchaser's specification.
- Pressure drop is 0.96 - 2.68"WC at rated flow (SCFM). Allow at least 5 duct diameters of straight duct upstream (inlet side) and downstream (outlet side) of the QUENCHER, otherwise pressure drop will be unpredictable.
- Dust Loading of up to 35-45 grains per cubic foot can be tolerated.

AUTOMATIC CELL CLEANER (not available with Mini-Quencher):

- A high pressure pulse is periodically injected to the air stream which blows out accumulated debris that may have settled in the turbulation cell.
- Standard voltage for diaphragm valve is 120 VAC/60 Hz, UL/ULC approval.

OPTIONS:

- ACCESS PORT on upstream side of Quencher assembly, c/w piano hinge and spring latch. Standard position as shown.
- FLOOR STAND / CEILING MOUNT BRACKET; to mount the Quencher on the floor or from the ceiling.
- UPGRADED CONSTRUCTION; SS=304 & 316 stainless steel, MD=medium duty for above 650°F, HD=heavy duty for abrasion and tough applications.
- NON-STANDARD INLET/OUTLET connections; Custom build, adds 2-4 weeks to delivery.
- COMPANION FLANGES; matching set of flanges for install on the duct.
- ROLLED EDGE adapter (for clamp together ducts); available for 6" to 24" duct, adds 5" to "C" or "D" dimension.
- SLEEVE JOINT (slip / raw edge) for slip on ducting, **not recommended for Q024 and larger models.**

CAUTION: For conditions other than standard air (70°F, 0% RH or moisture, sea level, and refrigeration cycle effects), consult factory. Selection of any spark arrestor must be done by a professional who knows how to make necessary adjustments when dealing with conditions other than ideal standard air.

- DO NOT Operate Below the Minimum SCFM
- Dimension "B" tolerance is + 0.500, depending on the material thickness.

Due to continuing product development and improvement; dimensions, specifications are subject to change without notice.

COMPANY		QUALITY AIR MANAGEMENT		ALL DIMENSIONS ARE IN INCHES UNLESS STATED OTHERWISE		PROJECTION	
Phone: 1-800-267-5585		www.qamanage.com		4	10/21/2020	corrected data	
				3	7/17/2020	added detail to the image	
				2	11/13/2019	added new models, deleted others	
TITLE		PAGE	DATE	SCALE	REV	REV. DATE	REVISION DESCRIPTION
Q-series Specifications (imperial)		1 OF 1	Sep 26, 2019	NTS	1	10/11/2019	replaces all previous versions
							DWG. NO. SA-001-1

QUENCHER Spark Arrestor

Cell Only Model

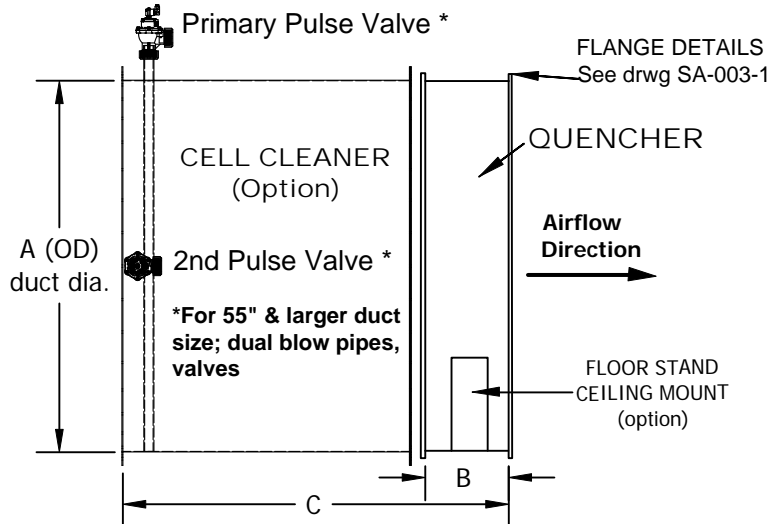

CONSTRUCTION:

- Built to; ISO 9001-2008 and CWB certified
- **Three styles are available;**
 1. QUENCHER STANDARD MODEL (Qxxx); includes transitions upstream and downstream to duct size.
 2. QUENCHER CELL ONLY (QCxxx); can be inserted into an existing duct, of equal diameter.
 3. MINI-QUENCHER; for high pressure vacuum systems
- Products are built to North American compliance with EPA, OSHA, NFPA, SMACNA round duct standards. Compliance with local codes and standards, and accuracy of order to job site operating conditions are the responsibility of the purchaser.
- HRS welded construction; QC008 to QC048 = 14 gauge, QC060 to QC084 = 12 gauge, QC096 = 10 gauge, good up to 650°F. Special construction available; SS=304 & 316 stainless steel, MD=medium duty for temperature above 650°F, HD=heavy duty for abrasion and tough applications.
- Paint Finish; Terra Brown RAL8028, outside surfaces, alkyline degreased, iron phosphate chemical etch, QC008 to QC072 are powder coated, QC084 TO QC096 are primed and top coat painted two part epoxy, good to 250°F. Special high temperature, corrosion and abrasion resistant finishes available upon request.
- Flanges and bolt pattern are according to the drawing SA-003 Flanges & Adapters. Others are available with purchaser's specification.
- Pressure drop is 0.96 to 2.68"WC at rated flow (SCFM). It is recommended to allow at least 5 duct diameters of straight duct upstream (inlet side) and downstream (outlet side) of the QUENCHER, otherwise pressure drop will be unpredictable.
- Dust Loading of up to 35-45 grains per cubic foot can be tolerated.

AUTOMATIC CELL CLEANER:

- a high pressure pulse is periodically injected to the air stream which blows out accumulated debris that may have settled in the turbulation cell.
- Standard voltage for diaphragm valve is 120 VAC/60 Hz, UL/ULC approval.

OPTIONS:

1. FLOOR STAND / CEILING MOUNT BRACKET; to mount the Quencher on the floor or from the ceiling.
2. UPGRADED CONSTRUCTION; SS=304 & 316 stainless steel, MD=medium duty for above 650°F, HD=heavy duty for abrasion and tough applications.
3. COMPANION FLANGES; matching set of flanges for the install on the duct.
4. ROLLED EDGE adapter (for clamp together ducts); available for 6" to 24" duct, adds 5" to "C" or "D" dimension.

CAUTION: For conditions other than standard air (70°F, 0% RH or moisture, sea level, and refrigeration cycle effects), consult factory. Selection of any spark arrestor must be done by a professional who knows how to make necessary adjustments when dealing with conditions other than ideal standard air.

Due to continuing product development and improvement; dimensions, specifications are subject to change without notice.

Dimensions: cubic feet per minute, inches, pounds

MODEL	SCFM (1) min - max	A (2) dia.	B	C	WEIGHT	WEIGHT w/ cell cleaner
QC008	500-810	8	6	25	9	27
QC010	800-1300	10	6	29	14	32
QC011	960-1600	11	6	29	16	35
QC014	1500-2400	14	8	35	25	47
QC016	2100-3300	16	8	38	35	60
QC020	3000-4900	20	10	45	55	85
QC024	4900-7600	24	12	49	75	114
QC026	5400-9000	26	12	49	80	125
QC030	7200-11,900	30	14	57	110	180
QC038	11,500-19,200	38	16	61	160	260
QC048	18,500-30,500	48	20	68	250	385
QC060	29,000-47,500	60	20	75	410	635
QC072	42,000-69,000	72	24	81	663	1166
QC084	57,000-94,000	84	24	84	874	1584
QC096	74,000-123,000	96	28	93	1210	1900

(1) DO NOT Operate Below the Minimum SCFM
 (2) There is a dimension tolerance of "B" + 0.500, depending on the material thickness..

COMPANY QUALITY AIR MANAGEMENT Phone: 1-800-267-5585 www.qamanage.com		ALL DIMENSIONS ARE IN INCHES UNLESS STATED OTHERWISE	PROJECTION
TITLE QC-series Specifications (imperial)	PAGE 1 OF 1	DATE Oct 16, 2019	SCALE NTS
REV. 1 11/14/2019 Update SCFM rating, dimensional specs	REV. 2 10/22/2020 data verification	REVISION DESCRIPTION	DWG. NO. SA-001-3

QUENCHER & CELL CLEANER

Standard FLANGES

MODEL	I.D.	O.D.	T	No. holes	Hole size	B.C.	L	M
Q008	6.094	8.	10ga(2)	6	9/32	7.313	3.625	5.675
Q010/Q011 QC008	8.125	10.25	10ga(2)	6	3/8	9.563	3.625	7.875
Q012/Q014 QC010	10.125	12.75	10ga(1)	6	7/16	11.813	3.625	9.875
Q016/QC012	12.125	15	10ga(1)	8	7/16	14	3.875	11.875
Q020/QC014	14.125	17	10ga(1)	8	7/16	16	4.875	13.875
Q024/QC016	16.125	19	3/16	8	7/16	18	4.875	15.875
Q026/QC020	20.125	23	3/16	12	7/16	21.75	4.875	19.875
Q030	22.125	25	3/16	12	7/16	23.75	4.875	n/a
QC024	24.125	27	3/16	12	7/16	25.875	4.875	n/a
Q038	28.125	32	3/16	14	7/16	30.375	n/a	n/a
QC030	30.125	34	3/16	14	7/16	32.375	n/a	n/a
Q048	36.125	40	3/16	16	7/16	38.375	n/a	n/a
QC038	38.125	42	3/16	18	7/16	40.25	n/a	n/a
Q060	44.125	48	3/16	20	7/16	46.25	n/a	n/a
QC048	48.125	52	3/16	22	7/16	50.25	n/a	n/a
Q072	54.125	59	3/16	28	7/16	56.75	n/a	n/a
QC060	60.125	65	3/16	30	7/16	62.75	n/a	n/a
Q084	62.125	68	1/4	32	7/16	65.50	n/a	n/a
Q096/QC072	72.125	78	1/4	36	7/16	75.50	n/a	n/a
Q108	80.125	87	1/4	40	7/16	84	n/a	n/a
QC084	84.125	91	1/4	42	7/16	88	n/a	n/a
Q120	88.125	95	1/4	44	7/16	92	n/a	n/a
QC096	96.125	103	1/4	48	7/16	100	n/a	n/a
QC108	108.125	115	1/4	48	7/16	112	n/a	n/a

(1) HD construction; T = 3/16 thickness
HRS construction

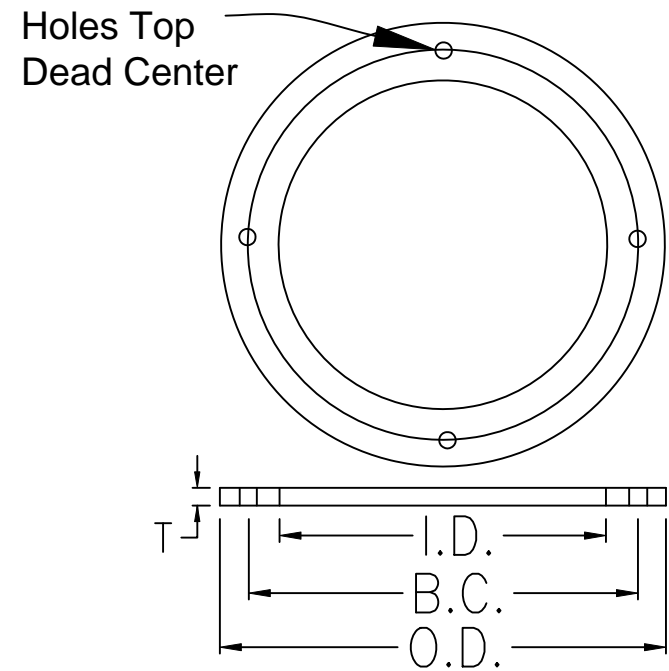

All dimensions in inches

SLEEVE / SLIP JOINT ADAPTER (2 req, one each end of Quencher) ROLLED EDGE ADAPTER (2 req, one each end of Quencher)

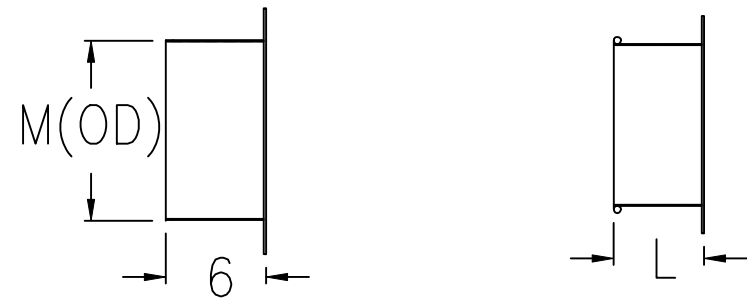

COMPANY:

QUALITY AIR MANAGEMENT

TITLE:

QUENCHER FLANGES AND ADAPTERS

DWG.No.

SA-003-1

REV. No.

DATE:

DATE:

March 24, 2020

SCALE:

NOT TO SCALE

DRAWN BY:

GRB

Pressure Drop (inches WC)

Pressure drop readings, taken in the field, are very difficult to rely on due to the extreme turbulence developed in the QUENCHER cell.

Dwyer Instruments Inc requires "smooth straight duct sections a minimum of 8.5 diameters in length upstream and 1.5 duct diameters downstream from a flow measuring device (i.e. pitot tube)". An accurate traverse of readings is necessary, per Dwyer specifications & Industrial Ventilation Manual. Provide an egg crate type straightener upstream from the measuring device. This will yield an accuracy of plus or minus 2%.

Remember to allow for the friction loss of these duct lengths and deduct from the pressure readings.

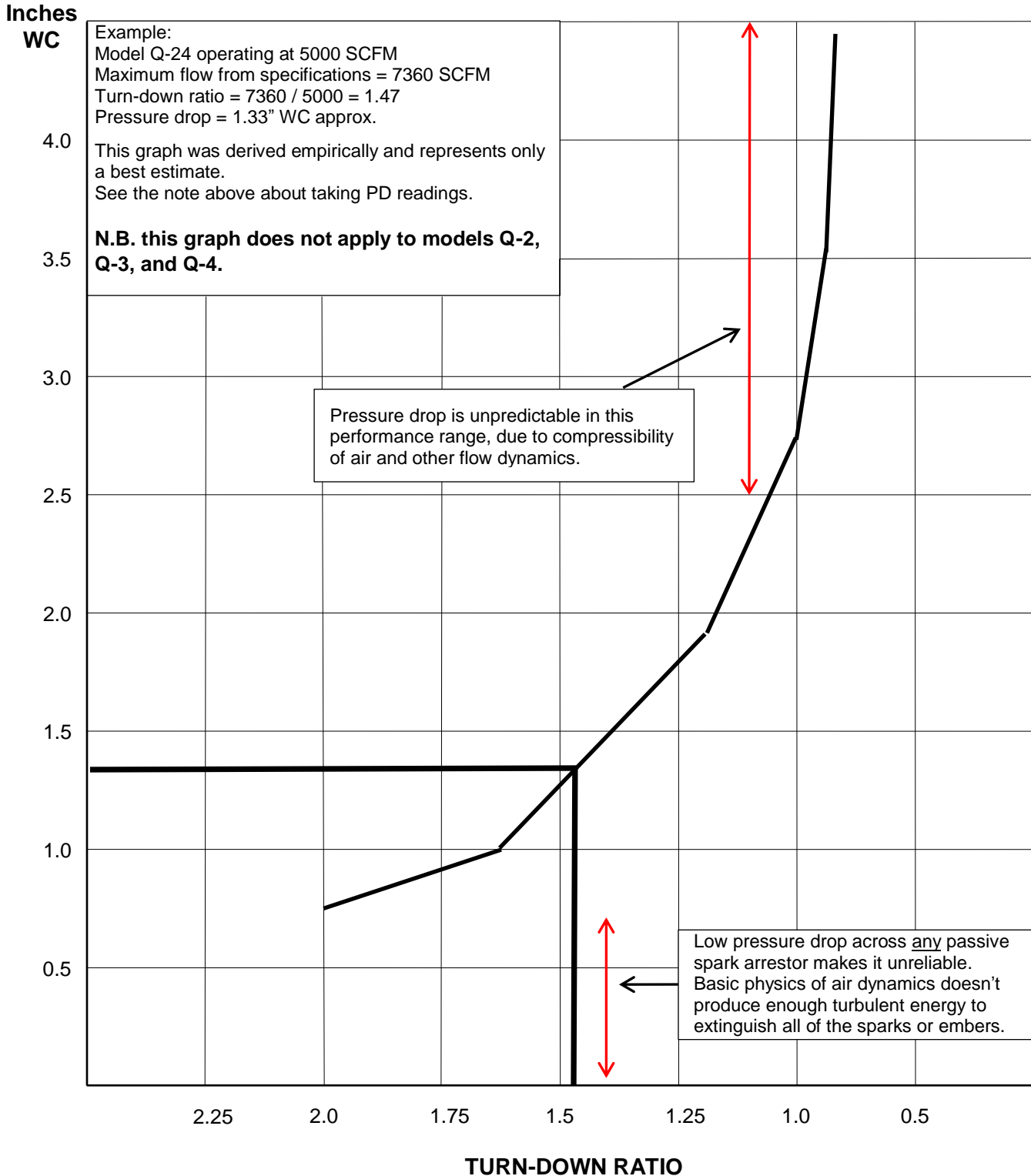

(A comparison of different methods)

Important Factors in Spark Arrestor Selection

- (1) **Make sure that the spark arrestor complies with NFPA 69 standard.** Request our bulletin “NFPA 69 & Quencher”.
- (2) There is no such thing as an efficiency rating for spark arrestors. They either work or they don't. Remember, it takes only one spark/ember getting through the device to cause a fire or explosion.
- (3) Maximum turbulence is the key to effective spark arresting and in the selection of a spark arresting device. Some devices do not impart enough turbulence (and/or pressure drop) to be 100% effective.
- (4) The recommended pressure drop for an in-line device (one that is installed in a section of the ductwork) is between 0.75 and 1.5 inches WC. Anything less is highly risky. This is a basic law of physics.
- (5) Pressure drop across a QUENCHER™ style of spark arrestor is a function of the Reynolds number which is proportional to the density for air. This means that a unit can be sized smaller if operating at a higher temperature. For instance a spark arrestor operating at 440 degrees F is 2/3 the size of the typical unit applied at 70 degrees F and the pressure drop will be designed the same. This lowers the cost of the spark arrestor and ensures its effectiveness. The density is also affected by the water vapor in the gas stream. It has little effect at temperatures below 125°F but can be a major factor when operating at higher temperatures.
- (6) If this unit is not kept clean, it might pose a threat; by putting an extra load on the ductwork, create a fire hazard, void the warranty. Without an automatic cell cleaner / booster system, the spark arrestor may require periodic manual cleaning. If the gas stream has dust that might drop out in the duct at the velocities in the blender style or QUENCHER™ spark arrestor, a booster must be provided to periodically remove this accumulation. The booster design is also temperature sensitive and must be altered to accommodate changing gas stream conditions.
- (7) Most suppliers do not have the capability to modify the designs as referred to in item (4), (5) & (6) above.
- (8) Design quirk; you cannot upsize or downsize models by simple ratio, as our competitors do. It won't work! Each model must have its own specific blade profile, to be effective.

Compare (below): Quencher to Spark Cooler (Blender Products), US DUCT Spark Trap, SparkShield (Plymovent), mesh filters, OEM spark traps, static drop out baffle-box (MicroAir), cyclones, static blade spark suppressor, liquid spray systems.

Improved In-Line Spark Arrestors

In 2005, QAM introduced the QUENCHER™ in-line spark arrestor to a virgin market to solve the common problem of fires in ducts and dust collection systems. Employing a 60 year old spin vane mist eliminator technology developed by Hosakawa Ltd of Japan and Sly Manufacturing in the early 1960's, led QAM to vary the blade designs to have **the most effective performance, inducing maximum turbulence to the gas stream, and lowering the cost.** Maximum turbulence (and the pressure drop that results from it) is the key to spark arresting. After several tests it was found that the air blending/mixer design did not impart enough turbulence and some sparks got through, especially at low gas stream velocities. Eventually, **there was a specific design which imparted the most effective swirling and turbulence thereby extinguishing the sparks quickly and most effectively.** In fact, during testing of the QUENCHER™, the arrestor cell would light up as a ball of fire, however, one inch past the cell nothing was left in the gas stream. These designs were incorporated into the QUENCHER™. QAM has developed special application data in which the blade angles are adjusted to produce minimum effective pressure drop for different temperatures and gas densities. To our knowledge, no one else accounts for the gas density effects on spark arrestors. In truth, due to the advanced design, even applying the incorrect parameters to a QUENCHER™ may not result in a failure to put out sparks. Since the pressure drop across the device is a function of the velocity through it, the development of **a pneumatically operated cell cleaner / booster was introduced to prevent dust dropout** accumulating in the static arresting cell. It also blows out accumulations on the blades.



Quencher overlapping blades

*“...and tested it last night. **It was quite amazing.** We put through a large continuous stream of sparks from a grinder and viewed it...”* Grant Stevens, Poxex Ltd.

Blender Type Air Mixers (marketed as “spark suppressors or coolers”)

A number of these air blender/mixers have been applied with varied success as in-line spark coolers, arrestors and suppressors. Over the last several years standard air mixers have been adapted and applied between the spark generating process and dust collector. They were applied in processes where fires in the dust collectors had previously occurred. One supplier hired a consultant to develop a market for these air blender/mixers as a spark arrestor/cooler. This air blending or mixer style design was an outgrowth of mixing two gas streams of different temperatures to insure a uniform temperature after the static mixer. It was deduced that the gas stream produced turbulent flow as it passed through the blades and this was the reason it could be adapted to spark cooling. However, **these are air mixers first and spark arrestors second**. They are marketed as having low pressure drop (maximum 0.5 inch WC) through them. There are **performance limitations** because **not enough turbulence (and related pressure drop) is imparted to the spark/ember**. To achieve spark suppression, we need to go from laminar to highly turbulent flow in the duct which strips away the hot air envelope around the spark/ember thereby cooling it and starving it of fuel (oxygen). For air blending this is not a requirement. Also, these devices have **large gaps between the mixing blades**, when looking through the inlet and downstream of the device. These gaps can **allow a percentage of sparks/embers to slip through** and cause a fire or even an explosion in the dust collector.

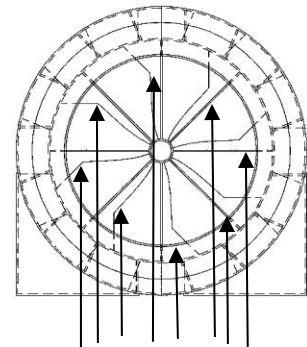

Large gaps where sparks can slip through and cause a fire or explosion.

*“In the past 18 months, we have had 4 fires. One fire destroyed the exterior dust collector... We have a Blender Products Spark Cooler... We believe we either have an issue with the Blender spark arrestor... I am looking to **replace an existing “Blender” style spark arrestor to improve the effectiveness of spark capture.**” Jim Jones*

The USPTO issued the results on a patent re-exam for the two patents regarding spark suppression devices, including the Spark Cooler. The re-exam was requested by Quality Air Management. The USPTO rejected or amended most claims made by Blender Products Inc. The USPTO action is based on existing patents and prior art, including the Quencher™ spark arrestor, that were not disclosed with the original patent application.

US DUCT Spark Trap (and other similar devices supplied by ducting companies)

A low value (cheap) device promoted for use with clamp together ducting, and **not for** more demanding industrial applications. It is very thin gauge construction (same as the clamp together duct), thus unreliable over the long term and subject to rapid wear and tear. This limits operating duct velocity to less than 3200 FPM. For any dust collection, they require an **additional drop-out collection point and sealed dustbin, causing unnecessary maintenance and defeating the purpose of the dust collector**. Needs easy access (clamp together section) for frequent clean out and maintenance. These cannot be installed vertically. Limited to maximum 24 inch duct size. **US DUCT own Disclaimer:** “no way represents...as a product that guarantees elimination of all sparks or reduction in risk of fire; designed only for light to moderate spark quantity; grindings are **HIGHLY** susceptible to falling out of the air stream and **WILL MOST LIKELY** collect in the bottom of the spark trap {Note how the air, sparks and dust is propelled to the outlet end, then must make a 180° turn back to the front of the unit where it enters the outlet tube. Much debris will jam at the back end and accumulate, eventually clogging the unit. If a live spark contacts this debris, you have a fire hazard.}; the purchaser is encouraged to install other spark elimination equipment...; distributed...without express or implied warranties of merchantability or fitness...”

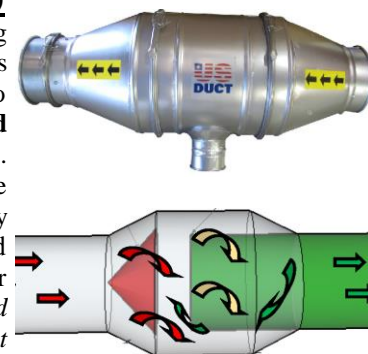

SPARKSHIELD by Plymovent, and other similar devices

“Virtually 100% efficiency” and “near to 100% protection” is just not good enough. It is described as a “cyclone spark arrestor”, so you need to read the section below on cyclones. They require an **additional drop-out collection point and dustbin, causing unnecessary maintenance**. Needs easy access for frequent clean out and maintenance. These cannot be installed vertically. Only three sizes, with very limited capacities ranging 600 – 7000 CFM @ very high pressure drop of 2.5” WC.



Mesh Filters

This is a common stop-gap measure where the filter is placed at the exhaust duct of hoods or installed in the ductwork. When clean, the mesh filter will stop at best 80% of sparks. These filters do not produce enough pressure drop to be fully effective. It only takes one spark to ignite dust in the duct or set a dust collector on fire. The only thing these filters do is clog up and add to your maintenance.



OEM Spark Trap

This is a recent type of spark arrestor developed by dust collection OEMs (such as Donaldson-Torit, Farr, ACT etc). It is an attempt to copy the in-line spark arrestors, referenced above, to offer an in-house equivalent. It is a simplification of those models, in fact an over simplification. **It doesn't work!** The problem is that it is only a perforated screen cone in the air stream. It acts as a filter and deviates the air but does not produce enough turbulence to effectively extinguish and cool sparks and/or embers. Actually, the mesh filter, referenced below, creates more turbulence. The larger particles hit the screen and drop down inside the device but the smaller sparks get through the screen and travel to the dust collector. It also is a high maintenance item and must be cleaned out regularly.

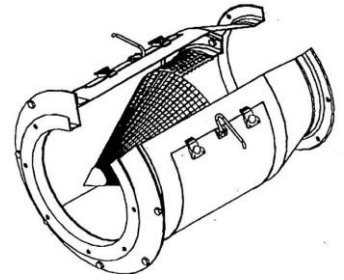

*“We purchased the spark trap with our Torit cartridge dust collector for our laser-cutting. We have had two fires in the dust collector in the past month and determined that **this device doesn't work and replaced it with a Quencher**. The only thing it seems to do is accumulate dirt in the device and we have to open the access ports to clean it out twice a day.” Jim Stanko*

Static Baffle-Box Spark Arrestor (drop-out box)

Many dust collector suppliers offer this type of device as a spark arrestor. It consists of air entering at one end of a baffle box running over a baffle plate which drops out the sparks and much of the dust collected. The air exits at the other end, and then travels to the dust collector. The big drawback is that a hopper and flexible or solid hose connection to a collection barrel is required. Also, these devices do not eliminate all of the sparks. There is not enough turbulence generated to ensure 100% spark arresting. Sparks may also ignite the contents of the collection bin under it.

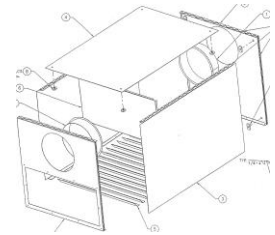

Cyclone Dust Collectors

Contrary to common belief cyclones are not effective spark arrestors. For a spark arrestor/cooler to work there must be high turbulence in the air stream. If you have turbulence in a cyclone the pressure drop is very high. Cyclones are designed to avoid turbulence. Many bag house fires occur in systems with cyclone pre-cleaners. Amazingly the inlet baffles on the baghouse are more effective as spark arrestors, however they are not foolproof.

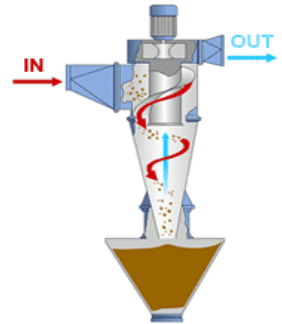

Static Blade Spark Suppressor (Tri Pass)

These were developed in Japan to replace multiple cyclones in coal fired boilers. They found that the multiple cyclones did not stop sparks from entering the dust collectors. The first ones were installed in the early 1970's. They ran at 1.5 inches of pressure drop and were fabricated from structural angles to resist the wear of the abrasive ashes in the coal that they fired. There are several of these applications installed in the USA and Canada designed by one of our colleagues. They have since given way to the “in-line” spark arrestors, referenced above, which are simpler, easier to maintain and operate at lower pressure drop.

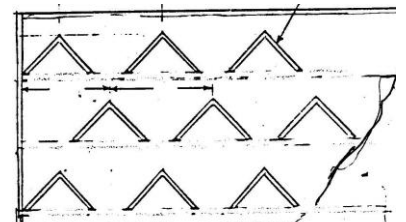

Liquid Spray Systems

These systems are extremely costly, messy to clean up, and for many years were the only method to prevent fires caused by sparks. The system consists of electronic detectors that detect sparks and react to their presence. When a spark is detected liquid sprays are actuated and water sprayed into the duct. The sprays actually cool the gas stream below the dew point. However, in dust collection systems, the water then wets the filter bags or cartridges. This prevents fires but the gas flow is interrupted and the bags must be either replaced or dried out before the process can resume. It takes a whole day or two to dry out the bags or even to prevent blinding and replacement. The detector sensitivity can be lowered to prevent excessive actuations, but, this reduces the reliability of the systems. The detector missing a spark is an ever present danger and a fire may occur. Bag or cartridge replacement is definitely required.

We trust that the above information will enable you to evaluate and select the most suitable method and supplier for your application. **Buying our QUENCHER / BOOSTER combination will give you a risk free unit, fine tuned for each application.**

Spark Arrestor Guide Specification

The spark arrestor shall be a static device, with no moving parts and electrical controls. The fixed overlapping curved blade assembly is designed to agitate the gas flow in a dust collection ducted system producing turbulent flow which strips oxygen away from and cools a spark or ember to within 50°F of the temperature in the process gas stream. It shall be constructed of hot rolled steel according to SMACNA “round industrial duct construction standards” or better.

The spark arrestor shall be an in-line device, requiring no dropout or collection recipient, inserted into the ducted system, attached by [flanges, slip connections or rolled edge clamped duct].

The spark arrestor must comply with NFPA 69 - Standard on Explosion Prevention Systems.

The spark arrestor must be designed specifically as a spark arrestor, not just a converted air mixing or air blending device, and, be equipped with an automatic electro-pneumatically operated integral cell cleaner / booster.

The spark arrestor shall condition the process gas stream without relying on injection of water, chemicals, or other retardants.

The spark arrestor must be rated for _____ ACFM (actual cubic feet per minute) at an air stream temperature of _____degrees F, for a _____inch (OD) duct connection, and a minimum pressure drop of 0.75 inches WC.

Acceptable product: **QUENCHER**[™] by Quality Air Management, phone; 1-800-267-5585, website; www.qamanage.com.

How does the Quencher stand up to NFPA 69, Standard on Explosion Prevention Systems?

The reader should be conversant with the entire NFPA 69 standard. Only pertinent excerpts are presented in this document.

SUMMARY: Although this standard applies mostly to automatic fire and explosion suppression systems, a chapter does cover static in-line spark arrestors. Some of the characteristics for compliance with the standard are:

1. **Quencher meets all the requirements of the standard. The low cost units and imitators, on the market, generally do not!** See for yourself by scrutinizing their literature and consulting our bulletin titled "Compare Spark Arresting Devices" against the presentation in this bulletin.
2. Passive Isolation Techniques (in-line static spark arrestors) are permitted under NFPA 69, but must meet very specific requirements to be accepted by the "Authority Having Jurisdiction".
3. Quencher isolates the ignition source and limits the oxidant concentration. Thereby preventing ignition in the gas stream downstream of the spark arrestor.
4. The supplier (manufacturer) of spark arrestors must clearly document safe installation and operating conditions to be met, and, be prepared to advise the end-user on specifically their application. *Only Quencher has the engineering capability and personnel to do this, and, provides complete comprehensive documentation to go with the product, its installation, operation and application.*
5. Unless it can be proven that all sparks/embers are extinguished, the standard requires additional elaborate spark and flame detection controls both upstream and downstream of the device. *Quencher does extinguish all sparks/embers when operated within its published design parameters, and therefore does not require these controls. No other product currently on the market will make that claim. They usually say "virtually all sparks are eliminated", and that is very different from Quencher's performance guarantee.*
6. Many in-line spark arrestors have a serious design flaw in that debris can build up in them and block the free flow of air in the system, which is a violation of this standard. *The Quencher is self-cleaning and prevents pressure build up.*
7. Many spark arrestors require a drop out conduit to release the sparks, and debris, into a separate collection drum or bin. This is a violation of paragraph 12.2.5.4.5 because it poses a fire and explosion hazard beyond the arrestor. *Quencher uses no such drop out provision.*

1.5 Equivalency; Nothing in the NFPA 69 standard prevents the use of spark arresting devices.

1.5.2; NFPA does not approve or certify anything. It is left up to the authority having jurisdiction.

3.3.16* Flame Arrestor; *Spark arrestors do not extinguish or stop a flame front. They will extinguish and cool the spark, reducing the likelihood of a fire.*

3.3.24.4 Ignition Source Isolation; This is what a good spark arrestor does. Not all spark arrestors are effective on 100% of the sparks/embers and therefore do not meet this definition. Quencher does.

3.3.25* Limiting Oxidant Concentration (LOC); Quencher strips the oxidant from the spark/ember, to below the concentration needed for a deflagration.

3.3.35 Self-Decomposing mixtures; Cellulose, paper, and the like, where a spark arrestor will not extinguish the spark/ember until the material is completely consumed and is strictly a spark/ ember. *This is a limiting factor in the effectiveness of a passive spark arrestor. The Quencher will tend to chop up the material into small pieces and accelerate the consumption of the material.*

4.2.2.2; Quencher prevents ignition in the gas stream and/or dust collection system downstream of the device.

5.2.3.1; Quencher prevents combustible material from attaining ignition temperature.

6.1.1 Methods based on the Prevention of Combustion; Quencher applies for “oxidant concentration reduction” around the spark/ember.

9.5.1.2 & 9.5.1.3 Process analysis; factors such as the type of combustible material, the enclosure internal geometry, the total volume to be protected, and the operating conditions shall be reviewed in detail. The potential process malfunctions that could affect the extent of the deflagration hazard shall be determined. *Our engineering personnel are the most qualified in the industry to undertake this and advise the end-user.*

9.6.1; The system manufacturer shall provide the owner or operator with information and documentation supporting the design; this information shall be suitable for review by the AHJ. *Quencher manufacturer is the only passive spark arrestor manufacturer capable of providing this.*

10.1.2; Enclosures that can be protected by a deflagration suppression system shall include dust collectors, pneumatic and screw conveyors and bucket elevators.

10.4.4.5 The system manufacturer shall provide to the owner or operator installation instructions, operating manuals, and maintenance instructions. *Quencher provides a detailed owner’s manual.*

12.2 Passive Isolation Techniques. Passive isolation system design shall be permitted to be based on various techniques that include, but are not limited to, the use of the following equipment: static dry flame arrestors

12.2.5.3 Static Flame Arrestor System Design; *passive spark arrestors fall under this category.*

12.2.5.4.4 Flame arrestors shall be installed and maintained in accordance with the manufacturer’s instructions. *Quencher provides detailed specifications for the proper operation of the spark arrestor. Most other devices provide very little or no instructions.*

12.2.5.4.5 In-line arrestors that can experience continued burning for a time longer than that for which they were tested or that are installed in a different orientation than in the approval test... shall meet the criteria in 12.2.5.4.5.1 through 12.2.5.4.5.4. *Unfortunately low end spark arrestors do not have such approval tests to refer to. The Quencher spark arrestor is designed and demonstrated to eliminate spark/ember in the arrestor cell and does not allow burning downstream of the arrestor cell. Therefore, Quencher is not required to comply with 12.2.5.4.5.1 through 12.2.5.4.5.4, which is rather involved.*

12.2.5.4.5.1 through 12.2.5.4.5.4; A means of detecting the burning shall be provided on both sides of the arrestor along with an alarm or automatic device to interrupt flow prior to failure. The response time for shutoff shall not extend beyond 1 minute. The shutoff temperature selected shall be determined on a case-by- case basis by, but not limited to, the following criteria: (1) The normal operating temperature of the vapor stream (2) The maximum operating temperature of the vapor stream (3) The vapor with the lowest auto-ignition temperature in the vapor stream. If thermocouples are used, they shall not be placed in thermowells unless specifically tested in that configuration.

12.2.5.4.6 The pipe diameter on the unprotected side shall be no larger than the flame arrestor inlet connection within 120 times the length-to-diameter ratio of the arrestor inlet. This is a common violation when designers oversize the ductwork.

12.2.5.4.7 The pipe diameter on the protected side shall be no less than the pipe diameter on the unprotected side, unless tested with a restriction on the protected side. Another common violation when designers undersize the ductwork.

12.2.5.4.8 Continuous monitoring of pressure drop shall be provided if the process is known to contain particulates or substances that may block the element and over-pressurize the system. Many competitive arrestors are designed to cause blockages within the spark arrestor unit. Quencher has no such restrictions and in fact provides an optional cell cleaner option to prevent any possibility of a blockage.

12.2.5.4.10 All parts of the flame arrestor shall be constructed to resist the expected mechanical, thermal, and chemical loads for the intended use. *Quencher is heavy duty industrial construction. Unfortunately, many other spark arrestors are flimsy light duty ductwork grade construction.*

12.2.5.4.14.2 Design shall allow internal inspection of flame filter elements. *Quencher offers an inspection “access door”.*

12.2.5.6.2 Use of these devices shall not apply to operational pressure outside the approved pressure range; special testing and approval shall be required if the operational pressure is exceeded. *Most spark arrestor suppliers do not provide the data to comply with this section. Quencher does!*

12.2.5.6.5 For in-line deflagration arrestors the ratio of pipe length (between the potential ignition source and the flame arrestor) and pipe diameter shall not exceed the tested ratio of length to diameter. *Quencher recommends at least a 5:1 length to diameter ratio, while others ignore any such stipulation.*

12.2.5.6.7 Use of these devices shall not apply outside the tested application limits. *Most devices have not been tested and therefore are not approved for use. Proper application of the QUENCHER does apply.*



The question is often asked, “How much straight duct is required before and after the Quencher spark arrestor?”

This gets quite technical:

1. We recommend at least 5 duct diameters upstream and downstream to ensure laminar flow entering the Quencher and re-establishing laminar flow leaving the device.
2. In fact, Dwyer indicates that you need at least 8 diameters of straight duct to get accurate static and velocity pressure readings, using common pressure reading devices.
3. **Consult the factory for solutions** if you have difficulty meeting this requirement.
4. If you are too close on the inlet and the air stream is turbulent or spinning in the same direction as our vanes impart, the spark may not tumble enough through the cell to get extinguished.
5. If you are too close on the inlet and the air stream is turbulent or spinning in the opposite direction as our vanes impart, you would add turbulence through the cell to extinguish the spark, which is good. However, this effect will cause the pressure drop to skyrocket exponentially. The pressure drop through the Quencher would be unpredictable.
6. If you have an elbow, or other flow changing device, too close to the inlet side, you can skew the profile of the air entering the Quencher. If the air is squeezed to one side of the Quencher cell, where you have higher volume flow and low volume flow on the other side, the area of low flow may actually run under the minimum flow required for spark arresting action. Sparks may fall out and ignite debris or just deviate through the Quencher, instead of having enough turbulent energy to be effective.
7. If you have an elbow, or other flow changing device, too close on the outlet side, the Quencher will only partially work to extinguish the sparks because you would skew the profile of the air through the Quencher. You would have the same effect as described in point #6 above. Also, the pressure drop rises exponentially through the combination of devices. It would be impossible to predict or assign a pressure drop through the devices, let alone the Quencher itself.
8. If you have the recommended length of straight duct before and after the Quencher, then our pressure drop chart (see separate bulletin) will be a good estimate of the pressure drop through the Quencher.
9. **CAUTION;** do not attempt a loop, as shown in the pictures below, to obtain recommended duct diameters. This is a disaster. You will dramatically choke the flow (by as much as 75%), skew the air profile entering the Quencher, increase pressure drop, and cause sparks to flow through the Quencher, due to lack of turbulent energy.

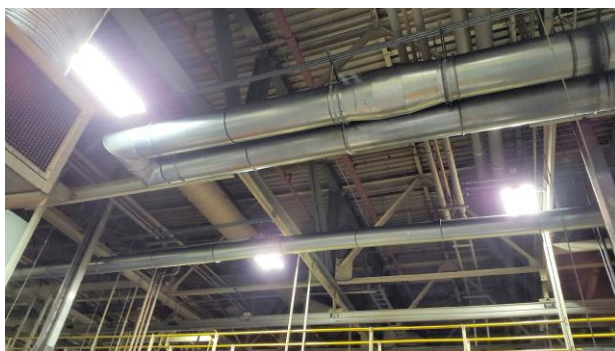

This is an over view of the potential for the **QUENCHER** in the ventilation market. It may seem detailed but the terms had to be defined as well as recent approaches. This can be exciting for all of us.

FOREWORD

Many gas steam processes, especially in powder collection systems, are candidates for the application of low cost spark arresting devices such as the **Quencher** supplied by Quality Air Management.

Note that embers & sparks get extinguished in the Quencher cell itself. Combusting material, such as paper or wood shavings, must be completely consumed within 4 duct diameters past the Quencher (where there is still enough turbulence) and taken the form of embers to be extinguished.

1) SPARK COOLING

Prevention of Sparks entering Solids separator (dust collector) equipment and starting fires

Definition: First we must define a spark. A spark is a piece of solid particulate which is completely oxidized and is at a temperature of 600 degrees F or over and which is above the ignition temperature of the powder being collected or above the ignition temperature of the filter elements.

Effects of sparks: Sparks can be carried along in the exhaust gas stream in laminar flow and will not cool off since cooling requires a difference in velocity between the gas and the spark being transported. Therefore, the spark will be carried into the solids separator and deposited on the filter element surface where it has a possibility of igniting the surface. If ignition occurs, the fire may spread and cause damage and produce harmful gases.

Response by the QUENCHER to sparks occurring in exhaust stream: The spark arrester converts the laminar flow to turbulent flow by thoroughly mixing the solid sparks with the gas stream, reducing the temperature of the sparks below the ignition temperatures of the filter media and the powder transported through the system.

2) HIGH TEMPERATURE COATING AND CUTTING PROCESSES

Originally a lot of these operations were performed by cutting with an acetylene torch to cut metal and with flame spray equipment which fed a wire into the flame of a gas torch to produce coating on various metallic and non-metallic surfaces.

The torch cuts were very coarse and had to be ground or put into other cold forming devices to make the parts usable. Often these cutting torches were applied to cutting up and reclaiming scrap. Most venting systems for torch cutting were vented into general ventilation and HVAC systems.

The flame spray equipment was limited to certain thicknesses and uniformity was such that on many parts subsequent grinding and smoothing operations were necessary. The coating produced was relatively coarse and the overspray was easily collected by low pressure drop wet powder collection devices. This avoided any requirements for mixing equipment.

The Advent of high temperature technologies was developed in the 1980-90's decade. Lasers, plasma, and arc tools have been applied to the processes long dominated by gas torches and sprays. These new technology systems are much more intense, quicker, more accurate and more efficient than the old gas flame units. The temperatures developed in the devices are sufficient to vaporize metals and actually increase the temperature above this value. These systems can take sharp cuts and make intricate cuts, cut fine round holes replacing shears, drill with little or no need for grinding or finishing. They can process thick plate or light gauge sheet metal with the same machinery. They are guided by CNC controls for maximum flexibility. Applying these processes to spray systems is also very effective. The spray process must be explained prior to treating the ventilation of the high temperature cutting devices. These are the fastest growing fabrication processes in the world.

Spray systems; These systems were vented into relatively large gas and powder over spray collection hoods. They produced particles with a very strong attraction to the parts being coated. Some have theorized that the bonding is at the molecular level. When it strikes the surface to be coated it bonds to the surface as if the coating was integral with the object that is in the path of the spraying device. The coating is either fed into the device as a powder or a wire.

The particulate overspray is relatively light in dust loading and the hood is vented to a dust powder collector. The wet collectors are not sufficiently effective to collect this much finer overspray. To develop sufficient collection efficiency, the overspray is vented to fabric or cartridge collecting device.

The overspray is still attracted to any solid it gets near and will form a hard impermeable coating which can seal the surfaces of filter collection elements. These overspray particles though much finer than the sparks described above are carried along in ducts which have laminar flow. They must lose their attractive ability before they reach the dust collector / powder separator. If the powder spray is given sufficient time in flowing through the duct work, it will lose its coating ability. Typically the residence time of the dust flowing in the duct, is designed for about one second and sometimes up to 1.5 seconds. For a system running at 2400 feet per minute at least forty feet of duct work would be required between the hood and the collector. Most plants do not have the room for these long ducts. We theorize that a QUENCHER element could allow the reduction of this residence time by as much as 90% and be more predictable than the residence time especially as newer spray compounds are being developed.

Venting High Temperature Cutting Systems; Although the dust venting from the cutting processes do not have as high an attraction as the coating guns, the dust has the same problem. Residence times are often in the 0.5 to 0.7 seconds. Because the dust loadings are so low and the customer often removes the coated filter elements and vents outside, the emissions will be lower than most air pollution codes. However, if the dust could be collected and neutralized, the savings in heating and cooling costs could pay for a QUENCHER device in a month or so.

3) GAS MIXING IN POWDER SEPARATORS

QUENCHER gas mixing cooling of gas streams

Usually all gas streams are designed for the lowest pressure drop to save on power consumption in moving the gas from one point to another. This is accomplished by moving the gas in a flow pattern called "laminar flow". In effect the gas stream is divided into cylinders that flow parallel in the duct work so that little or no mixing occurs between these cylinders within the walls of the ductwork. The other flow in a duct occurs when "turbulent flow" occurs. This is a violent mixing that occurs and will quadruple the pressure drop if it occurs in a length of duct. The gas follows the path of least resistance and naturally wants to revert to "laminar flow" when the disturbance or duct element, which produces the turbulent flow is removed. Both laminar and turbulent flow pressure drops are a function of the average velocity through the ducts.

If we mix two gas streams flowing through well designed transitions that maintain laminar flow in the total stream, the resultant is that the gas streams will continue in the duct with little or no mixing of the combined gas streams. For instance if a gas stream at 300 degrees F is mixed with one at 100 degrees F, the resultant gas stream will be stratified and continue through the system with part of the flow at 100 degrees and part at 300 degrees. There might be a very narrow layer of the flow that mixes.

The proprietary QUENCHER design is such that the whole cross section of the duct produces an effective mixing with a minimum penalty of pressure drop by producing turbulent flow through the mixing element.

Temperature Lowering Processes for Solids Separation

Some powder collection gas streams use various means to cool the powder laden gas streams by mixing ambient outside air to reduce the gas temperature (and associated powder temperatures) to a level where a fabric media powder collector can separate the powder and gas for subsequent collection of the solids. A typical operation of this type is on a clinker cooler system in a cement plant. The gas temperature may vary from 200 to 900 degrees F. For operation of the powder separator collector, the temperature entering the collector must be lowered to less than 500 degrees, usually 475 degrees. This can be accomplished by blending the ambient gas stream with process gas. When this mixture is designed, the resultant gas streams often remain stratified with low and high temperature streams entering the powder separator collector. In the past there were various schemes to mix these streams such as special duct fittings. However with these schemes, the air was mixed at high velocities which produced wear on the high velocity mixing components. Placing a QUENCHER in the gas streams achieves the cooling and mixing at minimal wear because of their low velocity designs. This application combines the most difficult circumstances that are likely to be faced in this type of circumstance.

4) FIRES IN POWDER SEPARATING SYSTEMS, CAUSES OTHER THAN SPARKS

There can be solids and liquids in exhaust systems that can cause fires in powder separation equipment.

Solids that are still burning when they enter the exhaust system; These can possibly develop into an explosion front entering the exhaust system. However more likely they will have the appearance of a spark in the exhaust system. A good example of this phenomenon is the collection of burning particles of paper usually strips. The paper provides both the oxygen and fuel to continue the burning process. The mixing process in the QUENCHER element may not cool the burning debris to lower it below the ignition temperature of the powder or filter media.

The solution is to completely oxidize the solids before it enters the collection device (dust collector) and associated spark cooler. In that case multiple QUENCHERS may speed up the oxidation and may be a field for future consideration in expanding the QUENCHER market. Another approach might be to install sprays of water prior to the Quencher and to modify the Quencher to separate droplets from the cooled gas stream. We can modify the Quencher designs to make them water droplet separators. (This was the approach taken at Mueller Brass. That service report confirms the efficacy of this approach.)

Spontaneous Combustion; Some metallic and other compounds will oxidize when mixed at room temperatures. This process is well documented when we hear of fires that are smoldering after a fire that suddenly break out into a full scale fire. Catalytic combustion where oxidation takes place between 120 and 300 degrees F is another example of this phenomenon. These fires can be prevented with a combination of QUENCHER and control changes to the powder dust collector operating and will be covered in a separate report in the future.

Explosions; Explosions in the exhaust system can and do trigger fires in collectors. The combustion produces a sustainable conflagration which travels through the ducts at very high speeds. While a QUENCHER mixer can reduce the effect of this flame front by lowering the intensity, the QUENCHER cannot be an approach to prevent explosions.

5) QUENCHER AS PART OF EVAPORATIVE COOLING SYSTEM FOR WET AND DRY POWDER SEPARATORS (DUST COLLECTORS)

In venting furnaces for metallurgical processes; Typically, these furnaces will exhaust at temperatures between 900 and 1800 degrees F. They are vented to either wet collection equipment or through fabric filter element powder collection equipment. As the gas stream enters

Wet Collectors; Wet collection equipment are called air washers or gas scrubbers. These collectors are most effective if the exhaust stream entering the collection device is close to 100% relative humidity, typically 120 to 160 degrees. The temperature is usually reduced by coarse water sprays. The humidification efficiency is usually 80 to 85 percent. The efficiency of the humidifier has a drastic effect on the collection efficiency of the wet collector. The addition of a QUENCHER will increase this humidification efficiency to over 95 per cent. This simple addition might improve collection efficiency to meeting the existing air pollution codes.

Dry Collectors; Many Industrial Processes such as insulation processes or making Mineral, fiberglass insulation, perlite processes develop the process in a furnace. Then the exhaust stream from the furnaces, containing the insulating batts or powder, must be separated from the exhaust stream. The separation device is a dry powder/dust collector. Collecting in a wet form will not produce a usable type of product. Normally the method of cooling is with an evaporative cooling tower that forms a wet cyclonic action from top to bottom. The purpose is to cool the dust laden gas stream to a temperature below 400 degrees F and with dew point temperatures that avoid condensing on the cooling tower walls, as the process temperature rises and falls. The humidifying is controlled to maintain the proper relationship of wet and dry bulb as determined by system operating parameters. Fogging nozzles and the control of the water spray rates is used to control the outlet temperature and humidification. The controls are complex because of the relatively low velocity of gases in the tower.

QUENCHER adaptation; the cooling tower would be replaced by a spray mounted in the high temperature ductwork. The QUENCHER would cause the water to evaporate completely and the spray would be increased by the temperature measured at the entrance to the powder collector. This would be more effective and reliable than the big bulky cooling towers which try to control the residence time of the droplets as they evaporate.

6) QUENCHER ADDS SAFETY TO WOODWORKING

Burning embers and sparks can be produced when, for example, cutting and transforming wood you strike a nail or staple. Embers are produced from kilns. You can use a spark arrestor with a fire suppression system, which is required by fire code and NFPA, by placing a QUENCHER upstream of the fire suppression system to extinguish most of the sparks and embers before they set off the suppression system and make a royal mess of the dust collector and duct system.

CONCLUSION

Every metal working, foundry, metal processing, cement and woodworking plant is a candidate for QUENCHER Technology.

Performance Guarantee for QUENCHER™ Spark Arrestors

The QUENCHER is a static turbulating device that operates by cooling glowing sparks/embers within the exhaust ducting system. By changing the characteristics of the gas flow, through the duct, from laminar to turbulent flow; it will cool sparks that are over 20 microns in diameter with an average grain loading of less than 10 grains per cubic foot of sparks. This change in type of flow causes a relative velocity difference between the sparks and the gas flowing past the sparks. It is effective when the air temperature in the process is lower than the spark temperature. The sparks will be cooled to within 20°F of the gas temperature in the duct and well below ignition temperature. The QUENCHER is suitable for spark arrestor duty and under the conditions described herein, will eliminate any sparks and embers from the air stream. It is a good safety device but no guarantee against all factors which cause fires/explosions.

The operating conditions are that the conveyed material has been completely combusted and is strictly in the form of embers before reaching the QUENCHER. The QUENCHER will not stop an explosion or flame front propagating in the duct and to the dust collector. It is not meant to be used in lieu of a fire or explosion suppression system. When the design of the process gas system mixes different gas streams at different temperatures, the QUENCHER functions as an air blender and will lower the mixture temperature to a theoretical value of a well mixed gas stream with a temperature gradient of approximately 20°F. The mixture must have a suitable mixture composition to prevent a flame from developing in and through the QUENCHER, as described above. The QUENCHER must be selected for gas flow of 1500–2500 FPM through the cell which is the CFM range stated on the product specification sheets. The effectiveness and pressure drop across the device is related to the gas density and volume flowing through the QUENCHER & cell cleaner, and, proper installation (such as respecting straight duct sections entering and leaving the device and vertical install limitations). *The QUENCHER can be supplied with a pneumatically actuated Booster-Cell Cleaner to prevent dust from settling in the relatively slow speed through the cell.*

Pressure drop through the device is excluded from the Guarantee and Warranty, due to its unpredictable nature.

An error in the selection or application, causing the possible return/exchange of a unit, with QAM authorization, must be claimed and received at the factory within 90 days of the original ship date, or, you will be expected to pay the full purchase price.

One Year Limited Warranty

The QUENCHER when purchased and installed for industrial use is warranted by Quality Air Management (QAM) to the purchaser for one (1) year against defects in material or, workmanship of the product. Any defective part in the product will be, at QAM's option, either repaired or replaced. The purchaser must return, with all transportation charges prepaid by said purchaser to Customer Service Department, Quality Air Management. The repaired or replacement part will, in turn, be shipped by QAM, to the purchaser, freight collect, with the purchaser to be responsible for all freight charges. The warranty on any repaired or replacement part shall be for duration of time no longer than the remaining or unexpired term of the original warranty. This warranty does not cover any labor or other service charges incurred by the purchaser.

Disclaimers and Exclusions

1. No warranty or technical support will be provided when there is a delinquent or past due payment by the purchaser.
2. **Complete jobsite and operating conditions must be provided, by the purchaser, either on our job survey forms or with the quote request or with the purchase order. Otherwise the performance guarantee and/or warranty shall be void.**
3. The warranty described hereinabove shall be IN LIEU of any other warranty, express or implied. Except as set out hereinabove, there are NO other warranties and any statutory or implied warranty of MERCHANTABILITY or fitness for a particular purpose is EXCLUDED from this transaction and shall not apply.
4. The purchaser agrees that his sole and exclusive remedy against QAM shall be for the repair or replacement of defective parts as provided hereinabove. The purchaser agrees that NO OTHER REMEDY (including, but not limited to, incidental or consequential damages for lost profits, lost sales, injury to person or property, or any other incidental or consequential loss) shall be available to him. The sole purpose of the stipulated exclusive remedy provided for herein, shall be to provide the purchaser with repair and replacement of defective parts in the manner provided for herein. This exclusive remedy shall not be deemed to have failed of its essential purpose so long as QAM is willing and able to repair or replace defective parts in the prescribed manner. The purchaser shall not be required to deliver a defective part to QAM, if:
 - (1) The part was destroyed as a result of its defect or any defect in any part covered in this warranty; and
 - (2) QAM is reasonably satisfied that the part was defective at the time of sale.

If both of these conditions are met, QAM will replace the part in the same manner provided herein as if the purchaser had delivered it to QAM.

5. The purchaser acknowledges that no oral statements purporting to be warranties, representations, or guarantees of any kind about any product of QAM, have been made to purchaser by QAM, or its dealer, which in any way expands, alters or modifies the terms of the warranty set out herein. Any such statements do not constitute warranties, shall not be relied on by the purchaser, and are not part of the contract of sale. This writing constitutes a complete and exclusive statement of the terms of any warranty, express or implied, of QAM.
6. There is NO WARRANTY for any defective part of a QAM product which has been removed from its original installation site or which arises from mishandling, neglect, fire, flood, lightning, corrosive atmosphere, improper installation of the product, unauthorized modification of the product, improper fuel or electrical supply to the product. There is NO WARRANTY for any defective part of a QAM product that arises from the failure of the purchaser to perform the normal and routine maintenance on the product as it is set out in the owner's manual. There is NO WARRANTY for any defective part of a QAM product that arises from a change of application, or collected contaminant from that which was initially specified.
7. The foregoing does not apply to components which were not manufactured by QAM or its licensee.
8. This warranty and all rights granted herein under shall be void and of no force or effect if consumable elements (i.e. filters) are replaced with elements that are not approved or supplied by Quality Air Management.